

DHT11 Based Temperature and Humidity Measuring System

Feresu ZTT^{1*}, Emmanuel Mashonjowa¹, Electdom Matandirotya¹

Department of Space Science and Applied Physics, University of Zimbabwe, Mt Pleasant, Harare, Zimbabwe

*Corresponding author: Feresu ZTT, Department of Space Science and Applied Physics, University of Zimbabwe, Mt Pleasant, Harare, Zimbabwe. E-mail: zferesu@gmail.com

Received date: 08 March, 2022, Manuscript No. JEEET-22-54675;

Editor assigned date: 11 March, 2022, Pre QC No. JEEET-22-54675 (PQ);

Reviewed date: 31 March, 2022, QC No. JEEET-22-54675;

Revised date: 22 April, 2022, Manuscript No: JEEET-22-54675 (R);

Published date: 29 May, 2022, DOI: 10.4172/jeeet.1000902.

Abstract

Temperature and humidity are very important parameters of the environment. This is shown in various industries like medicine, food, paper mills, textile, metrological, semiconductors, services etc.

The measurement of temperature and relative humidity remotely by using the appropriate sensors is not only important in environmental or weather monitoring but also crucial for many industrial processes. A device for weather monitoring has been developed as described in this paper to monitor and display the temperature and relative humidity of the atmosphere, using a digital component, the DHT11. The DHT11 is a basic, ultralow-cost digital temperature and humidity sensor. It measures the surrounding air and gives a calibrated digital signal output of the temperature and relative humidity. It is fairly simple to use. Historical and real time data can be accessed worldwide using the GSM network. The system can also be configured to transmit data on alarm or at pre-set intervals to a mobile phone using SMS text messaging.

Keywords: Temperature, Humidity, DHT11, Arduino, Thermometer

Introduction

The paper proposes a wireless solution, based on Global System for Mobile Communication (GSM) networks for the monitoring and control of humidity and temperature using the DHT11 sensor. The sensor is an economical peripheral [1]. It is capable of measuring relative humidity between 20 and 80% RH within the operating temperature range of 0 to 50°C with an accuracy of $\pm 5\%$ RH. Temperature is also measured in the range of 0 to 50°C with an accuracy of $\pm 2^\circ\text{C}$. The excellent advantages make DHT11 valued in the fields of automation and consumer electronics products. The monitoring of temperature and humidity are major areas in a weather station.

Monitoring of temperature and humidity are also required for biomedical industry for drugs and cell culture methods. In healthcare sectors, environment-controlled conditions are also required for patients. The sensor module is a combined module for sensing humidity and temperature which gives a calibrated digital output signal. It gives us very precise values of humidity and temperature.

In this paper we are going to measure temperature and humidity by using the DHT 11 together with an Arduino tool. The Arduino helps to collect data from the DHT11, and program it giving the required output display. It also gives application temperature and humidity which will be beneficial for balancing the environment to increase productivity in agriculture [2]. The clinical importance of measurement and control of humidity is illustrated. Commonly used methods of measuring humidity are described and their underlying physical principles are explained.

Materials and Methods

This system provides ideal solution for monitoring a weather station. This section describes how the data acquisition and reporting system was designed and constructed. The temperature and humidity data acquisition and reporting system will be designed according to the block diagram in Figure 1 below.

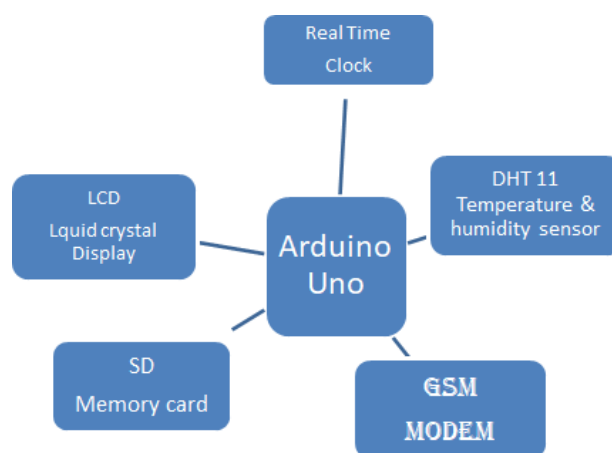

Figure 1: The temperature and humidity data acquisition and reporting system block diagram.

The temperature and humidity data acquisition and reporting system will use an SMS based system which is an automatic measurement and transmission of temperature and humidity data from remote stations using wireless system. This involves programming an Arduino microcontroller to take in inputs from meteorological sensors. The Arduino then sends messages to users scattered all over the region in the internet zone through a GSM modem. The liquid crystal display (LCD) shows the values onsite, the SD memory card keeps the temperature and humidity values and the real time clock (RTC) is for keeping the real time regardless of the battery power.

This design is based on a DHT11 which is used to detect temperature and humidity. The basic principle is that this device is very sensitive, low-cost, and easily controllable through electronic circuitry. The design attempts to match the sensor characteristics to those of the Pt100 platinum resistor for temperature and a dew point generator for the measurement of humidity. The system can also be configured to transmit data on alarm or at pre-set intervals to a mobile phone using messaging and this system also having the similar properties and some of the unique methods and designs are explained in the above reporting system block diagram. This system has the gsm modem, SD memory card, liquid crystal display, temperature sensor.

2.1 The Arduino Uno

The Arduino Uno is a microcontroller board based on ATmega328 (datasheet). It has 14 digital input/output pins (of which 6 can be used as PMW outputs), 6 analogue inputs, a 16 MHz ceramic resonator, a USB connection power jack, an ICSP header, and a reset button. It contains everything needed to support the GSM modem; simply connect it to a computer with a USB cable or power it with an AC-to-DC adapter or a battery. Arduino senses the environment by receiving inputs from many sensors and affects its surroundings [3] .

The Arduino Uno has some facilities for communicating with a computer, another Arduino, or other microcontrollers. The ATmega328 provides UART TTL (5V) serial communication, which is available on digital pins 0(RX) and 1(TX) [4].

Each of the 14 digital pins on the Uno can be used as an input or output, section pin Mode (), digital Write (), and digitalRead () functions. They operate at 5 volts. The Uno has 6 analogue inputs, labelled A0 through A5, each of which provides 10 bits of resolution (1024 different values.) [5]

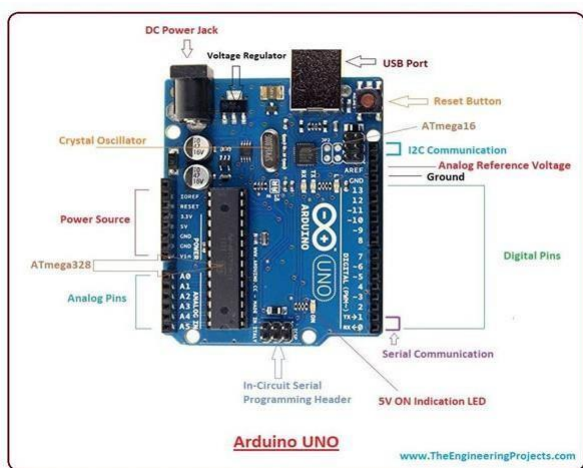

Figure 2: The Arduino Uno. (Arduino, 2018)

2.2 The DHT11, Temperature and Humidity Sensor

The DHT11 is a basic, ultralow-cost digital temperature and humidity sensor. It uses a capacitive humidity measuring element (with a measurement range of 20% to 80% and accuracy of $\pm 5\%$) calibrated against an NTC thermistor (with a measurement range of 0°C to 50°C and accuracy of $\pm 0.2^\circ\text{C}$) to measure the surrounding air and gives a calibrated digital signal output of the temperature and relative humidity (no analogue input pins needed). The only real downside of this sensor is that you can only get new data from it once every 2 seconds.

The DHT11 sensor module is a combined module for sensing humidity and temperature, which gives a calibrated digital output signal. A DHT11 gives us very precise values of humidity and temperature and ensures high reliability system and long-term stability. The automatic measurement and transmission of temperature and humidity of data from remote stations using wireless systems. It also involves in Arduino microcontrollers in meteorological sensors. The DHT11 sensor has a resistive type humidity measurement has its component and NTC type temperature measurement component with an 8-bit microcontroller inbuilt which has a fast response and cost

effective and available in 4-pin or 3-pin single row package.

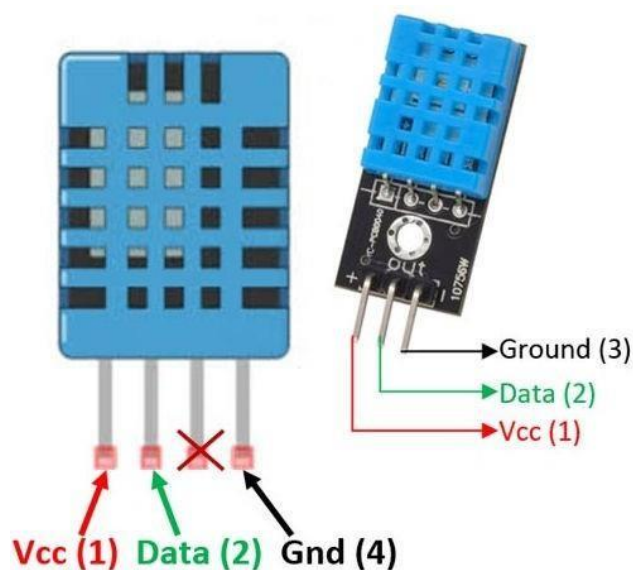

Figure 3: The DHT11 sensor (DHT11 Sensor Pinout)

The DHT11 module works on serial communication is single wire communication. This module sends data in form of pulse train of specific time period. Before sending data to Arduino, it needs some initialize command with a time delay. And the whole process time is about 4 ms. the single-wire serial interface makes system integration quick and easy. Its small size, low power consumption and up-to-20-meter signal transmission making it the best choice for various applications, including those most demanding ones [6]. It is convenient to connect and special packages can be provided according to users' request. This proposed system can provide a convenient method for effective monitoring of temperature and humidity in real time [7].

3.0 Results and Discussion:

3.1 Calibration of the DHT 11 Temperature and Humidity Sensor.

The temperature sensor of the DHT11 was calibrated against a Pt 100 platinum resistance thermometer, while the humidity sensor of the same component was calibrated against a dew point generator and dewpoint mirror measuring system. The basic principle of this device is low cost and easily cont. The dew point generator was used to provide a stream of air with a precisely controlled dew point, which had to be passed through an insulated hollow copper cylinder, approximately 20 mm in diameter and whose temperature was maintained at the same value as water circulating from a constant temperature water bath (model LTD6G) [8]. The DHT11 was placed in the copper cylinder and its temperature sensor calibrated over a temperature range from 20°C to 80°C by comparison against a Pt 100 platinum resistance thermometer placed in the same environment. The same stream of air was passed through the dew point mirror measuring system, and then the relative humidity of the airstream was calculated from the dew point and the temperature of the air stream as measured by the platinum resistance thermometer [9].

The relative humidity sensor outputs were calibrated over the range from 20% to 80% by comparison against the dew point measuring system-generated relative humidity values.

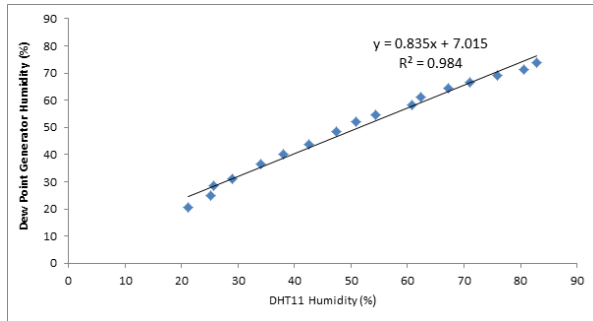

Figure 4: Calibration of the dew point generator against the DHT11 humidity sensor.

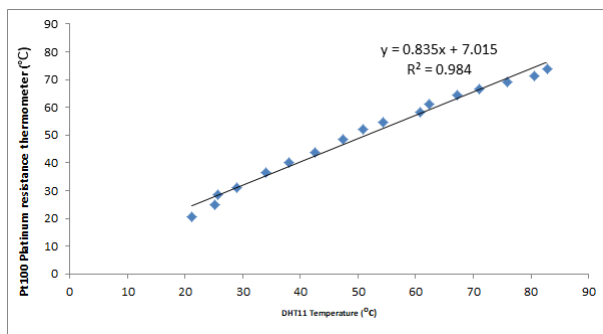

Figure 5: Calibration of the Pt 100 against the DHT11 humidity sensor.

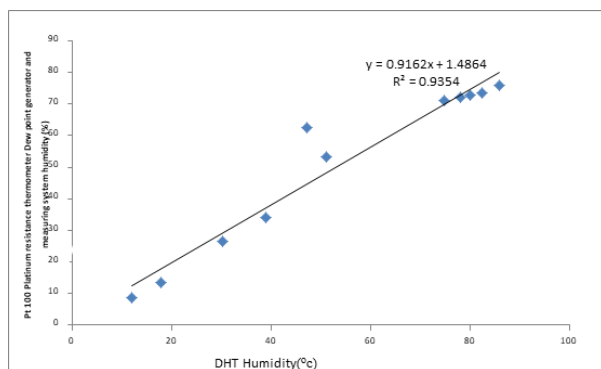

Figure 6: Calibration of the DHT11 temperature sensor against Pt100 platinum resistance thermometer

The graphical results are acceptable. The bulkiness of the standard temperature and humidity measuring equipment makes the small sized DHT11 temperature and humidity sensor handy. The TMP35, TMP 36 and TMP 37 are handy but can measure temperature only as compared to the DHT11 which measures both humidity and temperature.

Conclusion

This proposed system can provide a convenient method for effective monitoring of temperature and humidity in real time. This system is compact to an extent and cost effective. When compared to prices of instruments used traditionally to measure the environmental factors. From the above analysis, it is ensured that the nested wired systems can be replaced by the wireless sensor networks to get accurate data as well as to avoid many hazardous issues.

References

1. AOSONG (2010) Temperature and humidity. Datasheet 1–6.
2. Dong Z, Li I, Wang L, Quan XDM (2010) Design of the low cost silkworm house temperature and humidity automatic control system based on DHT11. Mod Agric Sci Technol 5: 18.
3. Bell C (2021) Introducing the arduino. in: Beginning IoT projects. Apress, Berkeley, 3: 31-70.
4. Saini H, Thakur A, Ahuja S, Sabharwal N, Kumar N (2016) Arduino based automatic wireless weather station with remote graphical application and alerts ICSPIN 3: 605–609.
5. Badamasi, YA (2014) The working principle of an arduino. ICECCO 9: 3-6.
6. Vimal PV, Shivaprakasha KS (2017) IOT based greenhouse environment monitoring and controlling system using arduino platform. ICICICT 7: 1514-1519.
7. Chachan R, Nayak SK, Champaty B, Paul K, Paul S et al. (2015) Designing of an intelligent temperature cum humidity monitoring system. INDICON 5: 1-6.
8. Kwon SY, Kim JC, Choi BI (2008) Accurate dew-Point measurement over a wide temperature range using a quartz crystal microbalance dew-point sensor. Meas Sci Technol 19: 115206.
9. Savage MJ (2010) Field evaluation of polymer capacitive humidity sensors for bowen ratio energy balance flux measurements. Sensors 10: 7748–7771.