



## Analysis of Electrical Power Disturbances in Distribution and Industrial Systems

Abraham Dandoussou<sup>1</sup>, Martin Kamta<sup>2</sup>, Frank Parfait Tchoundou<sup>1</sup>

### Abstract

The objective of this study is to clearly analyse by identifying and providing specifications on each disturbance. The main targets are the study of faults that suddenly happen on wires which supply loads, and the survey of detrimental effect coming from the load especially common loads used in industries. Simulation results were presented to illustrate analysis of these disturbances on a Distribution Line network. For single-phase earthing fault model, the results show the duration of the voltage sag of 90 ms with the magnitudes of 0 kV, 30.97 kV and 30.98 kV respectively for  $V_a$ ,  $V_b$  and  $V_c$ . For phase to phase fault model, the duration is around 85 ms with  $V_a = 21.3$  kV and  $V_b=V_c= 0$  kV. When using non-linear loads, the obtained THD varies from 32.10 % to 44.32 % and the total demand distortion (TDD) from 91.42% to 95.21 %.

**Keywords:** Power Systems, Power Disturbances, Industrial Systems, Total harmonic distortion

### Introduction

Electrical equipment is more sensitive to disturbances that arise both on the supply power system and within the customers' apparatus. Furthermore, this equipment is more interconnected in networks and industrial process so that the impacts of a problem with any piece of apparatus are much more severe. Nowadays, buses have been commonly used in industrial plants in order to change the mode of operating machines through the modification either of the supply voltage waveform, current waveform, frequency power system, or the direct and alternating currents. The use of static inverters in electrical energy distribution networks, considerably improve the system performances and effectiveness. Unfortunately, the inverters in general contribute to the degradation of the quality of the currents and voltages in the distribution networks. Indeed, the common occurrences of electric disturbances are due to the growing number of non-linear loads imposed on the electric lines, as the loads have the tendency to absorb non-sinusoidal currents and thereby introduce harmonic distortions

on the electric lines [1]. The increased concern analysis of power disturbance has resulted in significant advances in qualifying the distribution networks. Harmonics are one of the major types of disturbances to the ideal waveforms covered by the broader term of power quality disturbances [2]. Moreover in industries common disturbances occur and disturb switching control devices that are fired respect to voltage magnitude and angle. When the disturbance intrudes, it leads to the change of these parameters. Degradation in quality of power is mainly caused by disturbances such as voltage swell, voltage sag, notch, transients, and harmonic distortions and so on [3].

Table 1 shows some power disturbances according to IEEE. There are some period where distribution network encounter different sort of disturbance. Generally in Cameroon, from November to December, distribution network is overloaded with utilities apparatus and transformers are that saturated [3]. High harmonic distortion can negatively impact a facility's electric distribution system, and lead to excessive heat in transformers, causing early failures. Heat also builds up in wire insulation causing breakdown and failure. Load harmonics can cause the overheating of the magnetic cores of transformer and motors hence, produce skin effect. Increased operating temperatures can affect other equipment as well, resulting in malfunctions and early failure. This is load that disturbs the source. Switching ON/OFF of electronics devices which transform the current or voltage waveforms. Such happen to adjustable speed driver and causes huge financial losses, with the consequent loss of productivity and competitiveness. It is the source that disturbs the load. More over natural threat as storm even raining or wind could break down one, two or the three phases to ground such a way that a pylon fell down or shutdown, as well as create a large current unbalance that could blow fuses or trip breakers and completely destroyed the network system even customer's apparatus. These faults might cause voltage dips in one or more of the phases involved and may even indirectly cause over-voltages on the other phases. The system behaviour is then unbalanced by definition, but such phenomena are usually classified under voltage disturbances. Abnormal system conditions also cause disturbance either from the load or from the supplier [3].

Distribution line system often operated only at the primary substation that caused limitation of information. Distribution network also perplex due to various factors such as non-uniformity of line, uncertainty on fault resistance value, lateral branches, distribution loads and loading diversity. All this factors limited the use of some disturbances analysis techniques. Analysis of these disturbances is moving through

\*Corresponding author: Abraham Dandoussou; 1Department of Electrical and Power Engineering, Higher Technical Teachers' Training School, Kumba, University of Buea, Cameroon.

Received: 07 Aug, 2020 Accepted: 24 Aug, 2020 Published: 10 September, 2020

electrical parameters. Measurement and evaluation are geared throughout the distribution and the industries. Determining the start and end of the disturbance event is very important for analysis. Some suitable techniques for distribution network with limited data were proposed in [4]. These techniques compile iterative calculation to locate fault disturbance detection applying power quality information [5] [6]. The brightness principal is based on the fact that disturbance at distinct detections presents distinct waveform on characteristics. By identifying the patterns at different detection, the detection of fault can be determined. A recent method of fault detection using some disturbances was proposed in [7]. In this technique, an algorithm was introduced to identify the possible faulty section by matching the measured one with the disturbance wave shape in the database. The weakness of this method is the difficulty to clearly locate faulty section on the distribution network. There are several detection methods that are usually expressed in the terms of Hysteresis Voltage Technique, RMS Value Evaluation Method, Peak Value Evaluation Method, Novel technique and Missing Voltage Technique which are used to detect and analyse detrimental effects such as fault that happen or moved along the grid. Nonlinear loads are mostly the cause of harmonics, Fourier series analysis method that can be used to detect, analyse waveform phenomenon. The ability to express a non-sinusoidal waveform as a sum of sinusoidal waves can use the more common mathematical expressions and formulas to solve power distribution system problems [8].

This paper deals with the detailed study of power disturbances that occur firstly on distribution system network and secondly on industries. Clearly identify and provide specifications on each disturbance. Our main targets are the study of faults that sudden happen on wires whose supply loads, also survey of detrimental effect coming from the load especially common loads used in industries. Furthermore quantify through measured and evaluation in term of RMS (Vrms phase-phase, Vrms phase-ground) Time offset Period, discrete time power analysis in terms of THD and harmonics contents and on FFT of detrimental effects that move along the supplier up to loads common used in factories.

Table I. SOME EXAMPLES OF POWER DISTURBANCES ACCORDING TO IEEE

SI No	Disturbance	Short definition
A	Interruption	Voltage magnitude is zero
	Under voltage	Voltage magnitude is below its nominal value
	Over voltage	Voltage magnitude is above its nominal value
B	Voltage sag	A reduction in RMS voltage over a range of 0.1 – 0.9 pu for a duration greater than 10 ms but less than 1s
C	Voltage swell	An increase in RMS voltage over a range of 1.1 – 1.8 pu for a duration greater than 10 ms but less than 1s
D	Flicker	A visual effect of frequency variation of voltage in a system
E	Voltage/Current unbalance	Deviation in magnitude of voltage/current of any one or two of the three phases
F	Ringing waves	A transient condition which decays gradually
G	Outage	Power interruption for not exceeding 60 s duration due to fault or maltripping of switchgear/system
H	Transients	Sudden rise of signal
I	Harmonics	Non sinusoidal waveforms

## I. Power Disturbances Analysis Tools

### A. Fourier Analysis

The purposes of understanding, the following terms and definitions apply. The IEEE Standards Dictionary Online should be consulted for terms not defined in this clause. Harmonic is a component of order greater than one of the Fourier series of a periodic quantity. For example, in a 60 Hz system, the harmonic order 3, also known as the “third harmonic,” is 180 Hz. Interharmonic is a frequency component of a periodic quantity that is not an integer multiple of the frequency at which the supply systems operating (50 Hz or 60 Hz). The total demand distortion (TDD) is the ratio of the root mean square of the harmonic content, considering harmonic components up to the 50th order and specifically excluding interharmonics, expressed as a percentage of the maximum demand current. Harmonic components of order greater than 50 may be included when necessary. The total harmonic distortion (THD) is the ratio of the root mean square of the harmonic content, considering harmonic components up to the 50th order and specifically excluding interharmonics, expressed as a percentage of the fundamental. Harmonic components of order greater than 50 may be included when necessary. A great quantity of work has been focused in the estimation of amplitude and phase of the fundamental frequency as well as its related harmonics. A primary tool for estimation of fundamental amplitude of a signal is the discrete Fourier transform (DFT) or its computationally efficient implementation called fast Fourier transform (FFT). With this tool is possible to have an estimation of the fundamental amplitude and its harmonics with a reasonable approximation. FFT performs well for estimation of periodic signals in stationary state; however, it doesn't perform well for detection of suddenly or fast changes in waveform transients or voltages dips. Using it as analysing take into account distorted waveform, effective value, THD, effect of harmonic for power and power factor are analysed and presented using Fourier series [9][10].

The amount of distortion in the voltage or current waveform is quantified by means of an index called the total harmonic distortion (THD). According to IEEE 519-2014, it is defined as a ratio of the root-mean-square of the harmonic content to the root-mean-square value of the fundamental quantity and expressed as a percentage of the fundamental [2][9] [10] [11].

Equation (1)

$$\%THD_{V_{PCC}} = \frac{\sqrt{\sum_{h=2}^{\infty} V_{p, ch}^2}}{V_1} \times 100$$

According to IEEE 519-2014, the total effect of distortion in the current waveform at the PCC is measured by the index called the total demand distortion (TDD), as a percentage of the maximum demand current at the PCC. In other words, it is defined as a ratio of the root mean square of the harmonic content, (considering harmonic components typically up to the 50th order) to the root-mean-square of the maximum demand load current at the PCC and expressed as a percentage of maximum demand load current [2][9] [10] [11].

Equation (2)

$$\%TDD = \frac{\sqrt{\sum_{h=2}^{\infty} I_h^2}}{I_1} \times 100$$

Distortion factor expressed in terms of THD is given by

Equation (3)

$$\%DistortionFactor = \frac{1}{\sqrt{1+(THD)^2}}$$

B. RMS value algorithm

The basic idea is to follow the voltage magnitude changes as close as possible during the disturbing event. The more RMS values are calculated, the closer the disturbing event is represented, especially the non-rectangular variations. The RMS method represents one cycle historical average value, not instantaneous value which may lead to long detection time when event has occurred. The RMS voltage, related to power calculation, make it more suitable for the characterization of the magnitude of voltage or current disturbances. It consists of the voltage or current calculation, is integrated voltage or current waveform decomposition. Distribution network is modelled and many research are analysing them with RMS is based on the aver-aging of previously sampled data for one cycle. Therefore, it represents one cycle historical average value, not the momentary or instantaneous reading. Each of the sampled components of one cycle of the waveform is squared individually and then summed together. Then the square root of this sum is calculated and this single value is plotted [12][13] [14].

Equation (4)

$$V_{rms} = \sqrt{\frac{1}{T} \int_{t_0}^{t_0+T} V^2(t) dt}$$

Where T is the period of the signal. According to the definition of root mean value, the RMS voltage over one data window typically one cycle is done by using the following discrete integral equation [12][13] [14].

Equation (5)

$$V_{rms} = \sqrt{\frac{1}{N} \sum_{i=1}^N V_i^2}$$

In practical application, the data window is sliding along the time sequence in specific sample interval. In order to distinguish each result, time instant stamps labelled K are added to RMS voltage as independent variable [12][13] [14].

Equation (6)

$$V_{rms} = \sqrt{\frac{1}{2} \int_{i=k-N+1}^{i=k} V_i^2}$$

$$V_{rms} = rms(N) \quad k < N \text{ and } K1$$

Here N is the number of samples per cycle, is the instantaneous sampled voltage and K is the instant when the RMS voltage is estimated. Here RMS voltage is post estimated; RMS voltage is calculated with the previous N instantaneous voltage samples. Moreover, this algorithm is called one-cycle window, meaning that RMS values are estimated with one cycle of instantaneous values. Alternatively it is possible to estimate the RMS value using only half a cycle of instantaneous values. This algorithm is called half-cycle window [12][13] [14].

Equation (7)

$$V_{rms(1/2)}(k) = \sqrt{\frac{2}{N} \sum_{i=k-(\frac{N}{2})+1}^k V_i^2}$$

The half cycle algorithm is more sensitive to changes in the voltage and has a faster response to detect an event. However, the half-cycle algorithm shows oscillations when there is a second harmonic component in the voltage signal. Figure 1 shows the RMS voltage estimation using one-cycle algorithm and half -cycle algorithms. It also shows that the half-cycle algorithm is faster to detect the starting and ending of the events. Nevertheless, the event duration does not change considerably, both algorithms provide similar results. Furthermore, it can be verified that duration differences are rather small, and do not affect the estimation of sag indices.

Although root mean square (RMS) is not an inherent signal processing technique, is the most used tool. RMS gives a good approximation of the fundamental frequency amplitude profile of a waveform. A great advantage of this algorithm is its simplicity, speed of calculation and less requirement of memory, because RMS can be stored periodically instead of per sample [15]. However, its dependency of window length is considered as a disadvantage. One cycle window length will give better results in terms of profile than a half cycle window. Moreover, RMS algorithm does not distinguish fundamental frequency, harmonics or noise components. On the other hand, RMS voltage profiles are used for event analysis and automatic classification as proposed in [16].

C. Peak value evaluation method

Assume that the input voltage Vi(t) is given

Equation (8).

$$V_i(t) = V_p \sin(\omega t)$$

Where VP is the peak value of the input voltage. If Vi(t) to a 90degrees phase shit circuit, then vi'(t) is obtained as shown in

Equation (9).

$$v_i'(t) = V_p \sin(\omega t + 90^\circ) = V_p \cos(\omega t)$$

The two signals,  $v_i(t)$  and  $v_i'(t)$  are a pair of orthogonal function. If they are sent to two separate multipliers and squared, equations (10) can be derived.

Equation (10)

$$v_{01}(t) = KV_p^2 \sin^2(\omega t)$$

$$v_{02} = KV_p^2 \cos^2(\omega t)$$

Equation (11)

Where K is the multiplication factor of the multipliers. Due to the characteristic of orthogonal function it  $v_{01}(t)$  and  $v_{02}(t)$  is easy to obtain the square of the input voltage peak value by adding equations (9) and (10).

$$v_{0a} = v_{01}(t) + v_{02}(t) = KV_p^2 (\sin^2(\omega t) + \cos^2(\omega t)) = KV_p^2$$

Equation (12)

In order to measure the peak value, the signal  $v_{0a}(t)$  is fed to a square root circuit. Then the output of the square root circuit is given by equation (12).

$$v_0(t) = K_1 V_p$$

Where  $K_1$  is the multiplication factor of the square root circuit. when the multiplication factors of the multiplier and the square root circuit are selected properly, the value of constant  $K_1$  can be set as 1. The output voltage of the detector is equal to the peak value of the input voltage. Because the detector is based on the concept of an orthogonal function pair, it is called orthogonal detector [17] [18].

#### D. Missing voltage evaluation method

The Missing Voltage can be used to see the real time variation of the waveform from the ideal and the actual severity of the event. It is also capable to give more accurate indication of the duration of voltage sag/swell/interruption as well as the start and the end of event. The Missing Voltage Technique is defined as the difference between the desired instantaneous voltage and the actual instantaneous value. The desired voltage can be easily obtained by taking the pre-event voltage and extrapolating this out during the event which is similar to the way a phase-locked loop (PLL) operates. A PLL is a control loop incorporating a voltage control oscillator and phase sensitive detector in order to lock a given signal to stable reference frequency. Therefore, the desired voltage waveform will be known as PLL waveform ( $V_{PLL}(t)$ ) and it will be locked in magnitude, frequency, and phase angle to the pre-event voltage waveform [19] [20].

$$v_{pll}(t) = A \sin(\omega t - \phi_a)$$

$$v_{sag}(t) = B \sin(\omega t - \phi_b)$$

$$m(t) = R \sin(\omega t - \phi)$$

Equation (13)

with  $m(t)$  gives the instantaneous deviation of equation (15).

$$R = \sqrt{A^2 + B^2 - 2AB \cos(\phi_a - \phi_b)}$$

Equation (14)

And

$$\tan \phi = \frac{A \sin \phi_a - B \sin \phi_b}{A \cos \phi_a - B \sin \phi_b}$$

This method seems to be shown to be superior to the RMS method for sag analysis where phase angle jumps occur. It relies on the assumption that the system frequency is constant during the sag. Since the technique requires the RMS method to determine the amplitude of the pre-sag and sag voltages and, respectively. This method is suitable for sag analysis rather than detection but since its style need RMS it shows that the method is too long and fastidious [19] [20].

#### II. Simulation Models

For simulation purpose, electrical power distribution model is designed and the single-line diagram of the distribution model is shown in Figure 1. Using SimPowerSystem library of Simulink®, this model is simulated by applying various type of loads commonly seen in industries and faults like short circuit fault, heavy load, normal load, non-linear load (Power converter, efficient bulb lighting, etc.), and capacitor bank. The electrical power distribution model consists of a 25-kV voltage source and 50 Hz fundamental frequency. Each power quality events simulate for 10 cycles and a sampling frequency of 10 kHz. When single-line to ground fault is applied to bus 1 then, voltage sag and interruption are caused on faulty phase and voltage swell is caused on healthy phase. It is known that voltage sag, swell and interruption are also caused by switching on a heavy load but for simulation purpose we will target on faulty. Table 2 shows the specifications of the power distribution system used in the simulation. The performance study of sample system is carried out for detection and characterization of voltage due to power system faults. It is assumed that a fault has occurred at position short circuit fault, on the primary side of distribution transformer T2, and the fault lasted for 4 cycles from  $t = 0:045$  to  $0:125$  seconds.

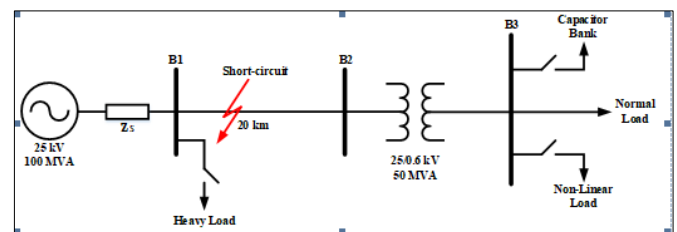

Figure 1. Single-Line diagram of the power distribution system

Table II. SPECIFICATION OF THE POWER DISTRIBUTION SYSTEM

Component	Details
Source	100 MVA ; 25 kV ; 50 Hz ; X/R = 10
Transformer N°1	50 MVA ; 25/11 kV ; Z = 7.15 Ω ; X/R = 10
Transformer N°2	50 MVA ; 11/0.22 kV ; Z = 7.15 Ω ; X/R = 10 Ω
Line 2	10 + j6 Ω ; 20 km
Loads	190 kW ; 130 kVAR

The Simulink® model of the system is given in figure 2.

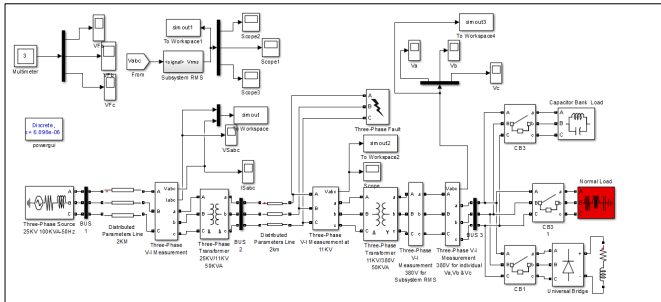

Figure 2. Simulink® model of the power distribution system

### III. Results and Discussion

#### A. Single-phase earthing fault model

Figure 3 shows the waveforms of the supply voltages  $V_a$ ,  $V_b$  and  $V_c$ . The single-phase earthing fault (phase A) has been introduced at time  $t = 0.08$  s. It can be observed that voltage  $V_a$  that is affected by the earthing fault becomes zero, while  $V_b$  and  $V_c$  have increased in magnitude. After the perturbation, the three voltages become normal.

Figures 4 and 5 show the RMS values of voltages  $V_a$ ,  $V_b$  and  $V_c$  respectively. During the earthing fault period, it is clear that:

- Voltage  $V_a$  drops to zero, with a duration of 91 ms. After the perturbation, it goes back to its normal value (42.66 kV) and stays there.
- Voltages  $V_b$  and  $V_c$  increase from the normal value (42.66 kV) to 73.62 kV, with a duration of 89 ms. The perturbation leads to a voltage swell of 30.97 kV.
- It is good to note that the choice of threshold may also affect the measurement of the duration for voltage drips with a slow recovery. These events occur during motor starting, transformer energizing, post-fault motor recovery and post-fault transformer saturation.

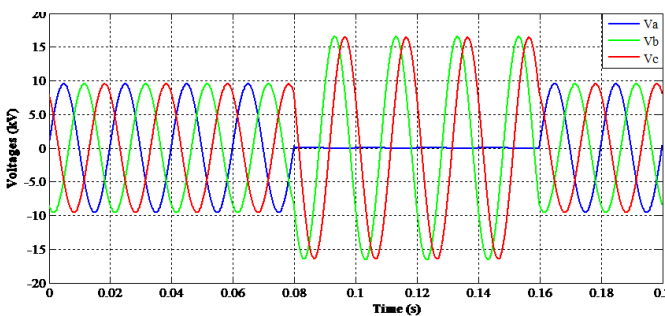

Figure 3. Waveforms of the supply voltages when applying a single-phase earthing fault

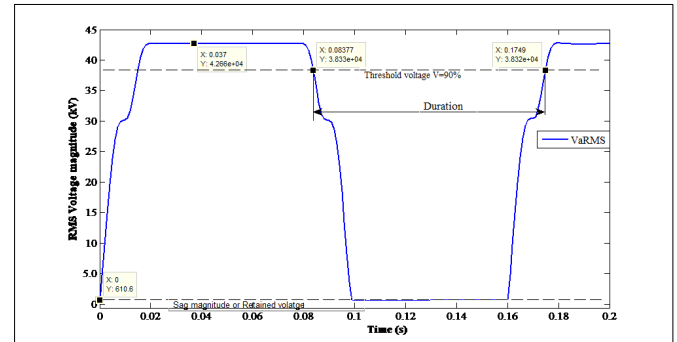

Figure 4. The RMS value of phase A voltage  $V_a$

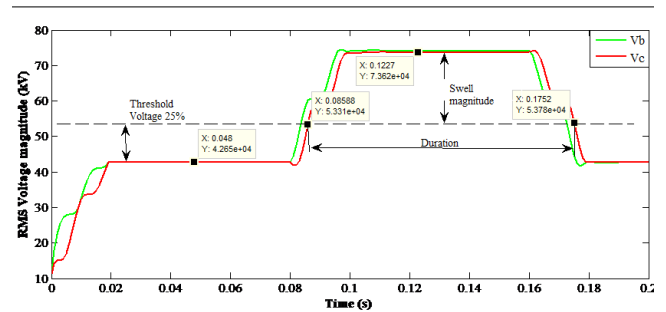

Figure 5. The RMS values of phases B and C voltages  $V_b$  and  $V_c$

#### B. Phase to phase fault model

The voltage sag starts when the RMS voltage  $U_{RMS}$  (1/2), drops below the threshold in at least one of the channels, and ends when the RMS voltage recovers above the threshold in all channels. The retained voltage for a multi-channel measurement is the lowest RMS voltage in any of the channels. During this fault, voltage of phase B, C drops with shake when phase to phase fault happens from 0.08s, voltage of phase B and C drop while voltage phase A rise and stop at 0.16 s. When the fault is cut off, voltages of phase B, C drop to normal.

A voltage sag and swell due to a two-phase-fault between phases B, C are presented figure 6. From these results, it is clear that there is a sudden reduction of the voltage sag at a point in the electrical system, followed by voltage recovery after a short period of time, from a cycle. Voltages are unbalance in phase-to-phase fault. The scheme shows that voltage sags are effectively characterised by the magnitude of the voltage, the duration and the depth. The Duration is the length of time for which the voltage remains below a threshold. In Figure 7, it is clear that the magnitude of phase A voltage grows with a magnitude of 21.34 kV for a duration of voltage swell equal to 85 ms. Figure 8, phases B and C lead to an urge voltage drop. The two voltages drop to a magnitude  $V_b = V_c = 0V$  when their duration of voltage sag is 81 ms.

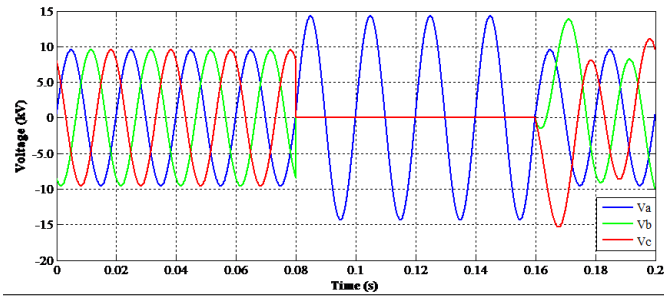

Figure 6. Waveforms of voltages Va, Vb and Vc for phase to phase fault

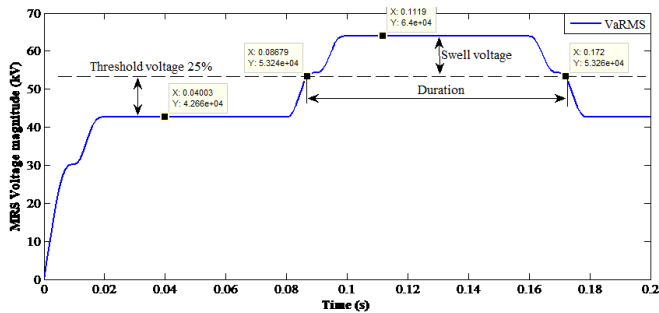

Figure 7. RMS value of voltage Va for phase to phase fault

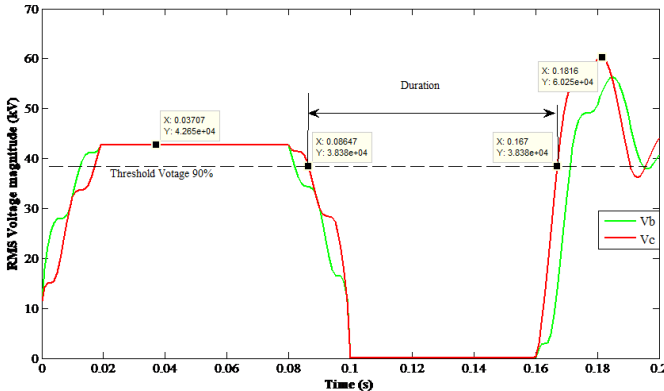

Figure 8. RMS values of voltages Vb and Vc for phase to phase fault

### C. Bank capacitor for transients

Supply voltage due to the operation of a capacitor bank produces transient. The capacitor bank creates transients type which is a disturbance. In fact the capacitor bank is energized when circuit breaker CB1 in Simulink model is switched on. As shown in figure 9, a transient is produced in supply voltage due to operation of a capacitor bank. The transient frequency depends upon the size of the capacitor bank. For the simulation,  $Q = 0.8$  MVAR

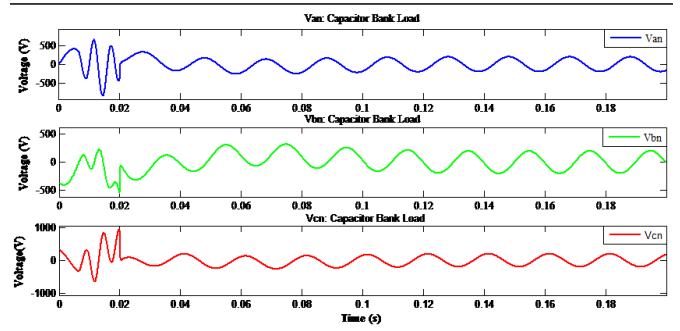

Figure 9. Waveforms of voltages Va, Vb and Vc for transient perturbations

### D. Non-linear load for harmonics

A load is considered non-linear if its impedance changes with the applied voltage. Due to this changing impedance, the current drawn by the non-linear load is also non-linear. The non-linear load is the source of harmonics. From the obtained results shown in figure 10 and in table 3, it should be noted that three-phase electrical power system distribution has high capacity non-linear load such as converter for electric motor control use to power drive in industries. The non-linear load of the power system is based on a three-phase bridge diode rectifier, also known as the six-pulse bridge because it is six pulses per cycle on the DC output. For the universal bridge made up of diode switched converters, the switching times are calculated relative to the zero crossings of line-to-line voltages at the terminal of the converter. To appreciate the impact of this phenomenon, there are two important concepts that should be kept in mind with regard to power system harmonics. The first is the nature of harmonic-current produced by loads (non-linear loads) and the second is the way in which harmonic currents flow and how the resulting harmonic voltages are developed at the end of the system.

The Fast Fourier Transform (FFT) tool in MATLAB®/Simulink® allows the computation of the fundamental component of voltage or current when simulation is running. This FFT tool of Powergui display the frequency spectrum of voltage Va waveform. This tool is very efficient because it computes the fundamental component and total harmonic distortion (THD) of the voltage Va. These efficient elements are displayed with an example of the spectrum window shown in figure 10. Harmonics are displayed in percentage of the fundamental component and they are given in table 3.

The obtained figure illustrates how the actual waveform can be approximated by summing. Comparing the waveforms results with those of literature, it can be observed that it is similar to other research works that are being carried out [21][22][23][24][25]. But since the simulations presented in these models differ from others, from the source to the loads, therefore voltage magnitude differ also. From the harmonics table, it is clear that harmonics computed on the distribution line show that the fundamental current angle, which is always lagging, is adjusted to yield the desired displacement of power factor. Harmonics phase angles are adjusted according to the time shift principle

to preserve wave shape appearance.

Table III. HARMONICS DETECTION ON PHASES A, B AND C

THD	Phase A	Phase B	Phase C
<b>THD (%)</b>	44.32	32.10	36.44
<b>TDD (%)</b>	91.42	95.21	93.95

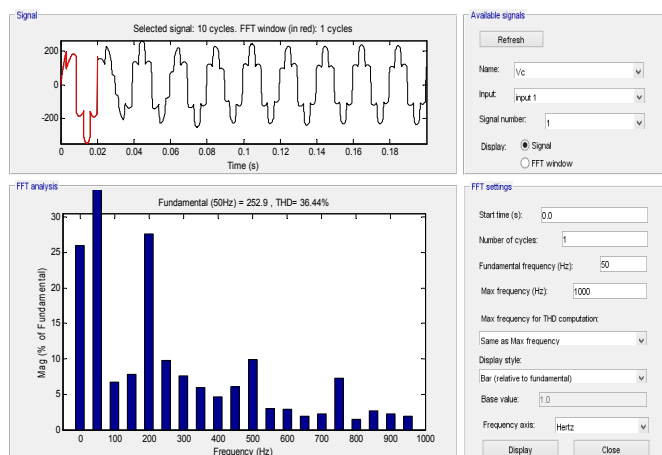

Figure 10. Total harmonics distortion

Conclusion

The power system which generates electricity, transports it and distributes it to consumers. When fault occurs, it causes disturbance to the power supply and disturbances to the power system mainly visible on distribution line. Such disturbance often leads to losses to the utilities, and customers mainly as industries. In order to minimize the losses and provide high quality of services, it is crucial for utilities to analyse disturbances as quickly as possible. The scope of this work is focused exclusively on the analysis of power disturbances in distribution and industrial systems. The indigence of examine leads to proposal of various automated analyse technics of this disturbance. In this research paper, many tools have been presented but one of them which is more accurate fault gives details on disturbance. Knowing how disturbances behave in the electrical network, it creates power fluctuations between the generating units and the electrical network. Results show that not all disturbances that occur are only caused by variety of conditions such as adverse weather conditions, animal contacts, equipment failure and accident leading to short circuit fault but are mainly caused by loads, with some which generate event inrushes on conductor. These perturbations affect sensitive load such that it can interrupt the whole production, and can break down the distribution grid. The performance of the technic is presented by testing it using an actual underground distribution network. The simulation results indicate the efficiency and accuracy, therefore a critical analysis is done to identify each of these disturbances. However, among several tools of analysis, the RMS method is one of the most

detectives that help to sense some disturbances. FFT is also applied to measure harmonics generated by non-linear load. Although, there are many different theoretical approaches that are used to measure diversification. In perspective, we would think of further analysis by focusing on sag/swell disturbances, their severity of individual events (single-event characteristics), by quantifying the performance at a specific location (single-site indices), and by quantifying the performance of the whole system (system indices) with respect to IEEE standard 1564-2014.

ACKNOWLEDGMENT

This research was carried out during the end of cycle project at the University of Buea, Cameroon.

REFERENCES

- [1] Akagi H. (1994), Trends in active power line. IEEE Transactions on Power Electronics, volume 9(number 3):pp 263–268.
- [2] Math H Bollen and Irene Gu. (2006) Signal processing of power quality disturbances. John Wiley And Sons, 30.
- [3] SHARMISTHA SARKAR. (2014), Power quality disturbance detection and classification using signal processing and soft computing techniques. Master’s thesis, National Institute of Technology (NIT) Rourkela, Roll No- 212EE5442, June.
- [4] Jun Zhu; D.L Lubkeman ; A.A Girgis (1997), Automated fault location and diagnosis on electric power distribution feeders. IEEE Transactions on Power Delivery, 12(number 2) pp 801–808, April.
- [5] A.Abur Z. Galijasevic. (2002), Fault location using voltage measurement. IEEE Transactions on Power Delivery, 17:pp 441–445, April.
- [6] M. Kezunovic J.R.S. Mantovani R.A.F Pereira, L.G.W. da Silva (2009), Improved fault location on distribution feeders based on matching during-fault voltage sags. IEEE Transactions on Power Delivery, 24 pp 441–445, April.
- [7] H.Y.Li A.R Khalid H.Mokhlis (2010), The application of vaoltage sags pattern to lo-cate a faulted section in distribution network. International Review of Electrical Engineering (IREE), 5(number 7):pp 173–179, February.
- [8] John Cherney, (2003), harmonics analysising distribution. IEEE,.
- [9] M A S Masoum, E F Fuchs (2008), Power quality in power system and electrical machines. 2nd Edition: Academic Press.
- [10] Suresh Kamble and Dr. Chandrashekhar Thorat, (2012), Characteristics analysis of voltage sag in distribution system using rms voltage method. ACEEE Int. J., 03(01):55–61, February
- [11] N.R Watson J. Arrillaga, (2003), Power system harmonics. John Wiley And Sons.

- [12] Raj Naidoo and Pragasen Pillay, (2007), A new method of voltage sag and swell detection. IEEE TRANSACTIONS ON POWER DELIVERY, 22(2):1057– 1063, April.
- [13] A. S. Mokhtar NAM Ismail S. Khokhar, A. A. Mohd Zin, (2014), Matlab/Simulink based modelling and simulation of power quality disturbances. IEEE, (2):4799–4848.
- [14] Z.Zou Y.Yang, F.Blaabjerg, (2012), Bench marking of grid fault modes in single-phase grid-connected photovoltaic systems. page 437, September.
- [15] Damir Novosel Steven Kunsman Carl LaPlace David Hart, David Uy and Marco Tellarini, (2000), Improving power quality. ABB Review, page 4.
- [16] Math Bollen Emmanouil Styvaktakis and Irene Gu, (2012), Automatic classification of power system events using rms voltage measurements. Submitted for publication in IEEE Transactions on Power Delivery.
- [17] O. C. MONTRO-HERN' ANDEZ and P. N. ENJETI, (2005), A fast detection algorithm suitable for mitigation of numerous power quality disturbances. IEEE Transactions on Industry Applications, 41(6).
- [18] Yongheng Yang and Frede Blaabjerg, (2012), Low-Voltage Ride-Through Capability of a Single-Stage Single-Phase Photovoltaic System Connected to the Low-Voltage Grid. PhD thesis, Aalborg University, <http://dx.doi.org/10.1155/2013/257487>, December ID 257487.
- [19] Jr. P.R.Chaney N.S. Tuna boylu, E.R, (1998), Collins. Voltage disturbance evaluation using the missing voltage technique. In International Conference on Harmonics and Quality of Power, volume 1, pages 577–582.
- [20] X. D. Xue et al D. Kai, K. W. E. Cheng, (2006 ), A novel detection method for voltage sags. pages 250–255.
- [21] Abdelhay A.Sallam Abdelazeem A.Abdelsalam, Azza A.Eldesouky, (2012), Characterization of power quality disturbances using hybrid technique of linear kalman filter and fuzzy expert system. ELSEVIER Electric power system Reaserch, 83:41–50.
- [22] T. Larsson A. Sannino, J. Swensson, (2003), Power-electronic solutions to power quality problems. Electric Power Systems Research, pages 66:71–82.
- [23] J. J. Burke and D. J. Lawrence, (1983), Characteristics of fault currents on distribution systems. IEEE Transactions on Power Apparatus and Systems, PAS-103(1):1–6, January 1984 1984. EPRI 1209-1.
- [24] M.H.J. Bollen, (2000), Understanding power quality problems:voltage sags and interrup-tions. New York, IEEE Press.
- [25] M. Bollen, (2001), Voltage sags in three-phase systems. IEEE Power Eng, 12(number 2):pp. 8–15 Review.

### Author Affiliation

Top

<sup>1</sup>Department of Electrical and Power Engineering, Higher Technical Teachers' Training School, Kumba, University of Buea, Cameroon.

<sup>2</sup>Department of Electrical Engineering, Energetic and Automation, National School of Agro-Industrial Sciences, University of Ngaoundere, Cameroon.

### Submit your next manuscript and get advantages of SciTechnol submissions

- ❖ 80 Journals
- ❖ 21 Day rapid review process
- ❖ 3000 Editorial team
- ❖ 5 Million readers
- ❖ More than 5000 
- ❖ Quality and quick review processing through Editorial Manager System

Submit your next manuscript at • [www.scitechnol.com/submission](http://www.scitechnol.com/submission)